

## Spring latches

Steel / Stainless Steel, with flange for surface mounting, parallel to the plunger pin

### SPECIFICATION

#### Types

- Type **L**: left indexing cam
- Type **R**: right indexing cam

#### Version in Steel ST

- Guide  
Steel precision casting
- zinc plated, blue passivated **ZB**
- zinc plated and plastic coated  
black, textured finish **SW**

#### Latch

Steel, zinc plated, blue passivated

#### Plunger pin

Steel, zinc plated, blue passivated

#### Spring

Stainless Steel AISI 316Ti

#### Version in Stainless Steel A4

- Guide / Latch  
Stainless Steel precision casting **A4**
- AISI 316
- Plunger pin  
Stainless Steel AISI 316
- Spring  
Stainless Steel AISI 316Ti

### INFORMATION

With spring latches GN 722.3, the plunger pin is retracted over the curve of the guide by a 180° turn of the latch. The notch at the upper end of the curve causes the latch to be held in place if the plunger pin needs to be kept temporarily from protruding. The **ZB** and **SW** versions are designed for applications in steel construction, whereas the **A4** stainless steel version is suitable for use in particularly aggressive environments.

The dimensional tolerances between plunger pin and guide are selected so that the functional reliability is guaranteed even after welding, applying a corrosion protection layer or in case of contamination

For fastening, slotted or hexagonal mounting holes allow the use of socket cap screws DIN 912 and hexagon screws or nuts according to DIN 931 or DIN 934.

- Range of cam action indexing plungers (see page 738)



### TECHNICAL INFORMATION

- Stainless Steel characteristics (see page A26)
- Load rating information (see page A42)

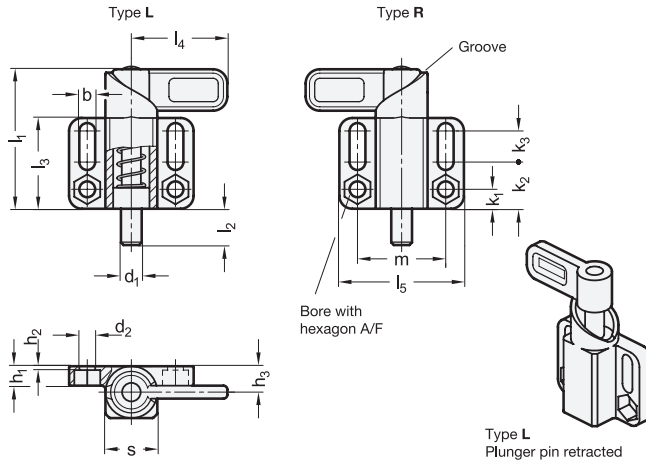

GN 722.3-ST

| Description         | d1<br>Pin -0.05/-0.25<br>Bore +0.1/+0.3 | s  | b<br>+0.3 | d2<br>+0.2 | h1  | h2  | h3 | k1  | k2 | k3 | l1 ≈ | l2 | l3 | l4 | l5 | m  | A/F | Spring load<br>in N ≈<br>initial | Spring load<br>in N ≈<br>end | ⚖   |
|---------------------|---|----|-----------|------------|-----|-----|----|-----|----|----|------|----|----|----|----|----|-----|----------------------------------|------------------------------|-----|
| GN 722.3-8-20-R-SW  | 8                                       | 20 | 6.1       | 6.1        | 7.5 | 1.5 | 10 | 7.5 | 18 | 12 | 54   | 14 | 35 | 37 | 48 | 34 | 10  | 15                               | 50                           | 179 |
| GN 722.3-8-20-R-ZB  | 8                                       | 20 | 6.1       | 6.1        | 7.5 | 1.5 | 10 | 7.5 | 18 | 12 | 54   | 14 | 35 | 37 | 48 | 34 | 10  | 15                               | 50                           | 179 |
| GN 722.3-10-20-R-SW | 10                                      | 20 | 6.1       | 6.1        | 7.5 | 1.5 | 10 | 7.5 | 18 | 12 | 54   | 14 | 35 | 37 | 48 | 34 | 10  | 15                               | 50                           | 180 |
| GN 722.3-10-20-R-ZB | 10                                      | 20 | 6.1       | 6.1        | 7.5 | 1.5 | 10 | 7.5 | 18 | 12 | 54   | 14 | 35 | 37 | 48 | 34 | 10  | 15                               | 50                           | 180 |
| GN 722.3-12-20-R-SW | 12                                      | 20 | 6.1       | 6.1        | 7.5 | 1.5 | 10 | 7.5 | 18 | 12 | 54   | 14 | 35 | 37 | 48 | 34 | 10  | 15                               | 50                           | 186 |
| GN 722.3-12-20-R-ZB | 12                                      | 20 | 6.1       | 6.1        | 7.5 | 1.5 | 10 | 7.5 | 18 | 12 | 54   | 14 | 35 | 37 | 48 | 34 | 10  | 15                               | 50                           | 186 |
| GN 722.3-14-20-R-SW | 14                                      | 20 | 6.1       | 6.1        | 7.5 | 1.5 | 10 | 7.5 | 18 | 12 | 54   | 14 | 35 | 37 | 48 | 34 | 10  | 15                               | 50                           | 199 |
| GN 722.3-14-20-R-ZB | 14                                      | 20 | 6.1       | 6.1        | 7.5 | 1.5 | 10 | 7.5 | 18 | 12 | 54   | 14 | 35 | 37 | 48 | 34 | 10  | 15                               | 50                           | 199 |
| GN 722.3-16-30-R-SW | 16                                      | 30 | 10.1      | 10.1       | 15  | 5   | 15 | 14  | 34 | 10 | 83   | 20 | 54 | 55 | 80 | 55 | 17  | 30                               | 110                          | 846 |
| GN 722.3-16-30-R-ZB | 16                                      | 30 | 10.1      | 10.1       | 15  | 5   | 15 | 14  | 34 | 10 | 83   | 20 | 54 | 55 | 80 | 55 | 17  | 30                               | 110                          | 846 |
| GN 722.3-20-30-R-SW | 20                                      | 30 | 10.1      | 10.1       | 15  | 5   | 15 | 14  | 34 | 10 | 83   | 20 | 54 | 55 | 80 | 55 | 17  | 30                               | 110                          | 863 |
| GN 722.3-20-30-R-ZB | 20                                      | 30 | 10.1      | 10.1       | 15  | 5   | 15 | 14  | 34 | 10 | 83   | 20 | 54 | 55 | 80 | 55 | 17  | 30                               | 110                          | 863 |
| GN 722.3-8-20-L-SW  | 8                                       | 20 | 6.1       | 6.1        | 7.5 | 1.5 | 10 | 7.5 | 18 | 12 | 54   | 14 | 35 | 37 | 48 | 34 | 10  | 15                               | 50                           | 179 |
| GN 722.3-8-20-L-ZB  | 8                                       | 20 | 6.1       | 6.1        | 7.5 | 1.5 | 10 | 7.5 | 18 | 12 | 54   | 14 | 35 | 37 | 48 | 34 | 10  | 15                               | 50                           | 179 |
| GN 722.3-10-20-L-SW | 10                                      | 20 | 6.1       | 6.1        | 7.5 | 1.5 | 10 | 7.5 | 18 | 12 | 54   | 14 | 35 | 37 | 48 | 34 | 10  | 15                               | 50                           | 180 |
| GN 722.3-10-20-L-ZB | 10                                      | 20 | 6.1       | 6.1        | 7.5 | 1.5 | 10 | 7.5 | 18 | 12 | 54   | 14 | 35 | 37 | 48 | 34 | 10  | 15                               | 50                           | 180 |
| GN 722.3-12-20-L-SW | 12                                      | 20 | 6.1       | 6.1        | 7.5 | 1.5 | 10 | 7.5 | 18 | 12 | 54   | 14 | 35 | 37 | 48 | 34 | 10  | 15                               | 50                           | 186 |
| GN 722.3-12-20-L-ZB | 12                                      | 20 | 6.1       | 6.1        | 7.5 | 1.5 | 10 | 7.5 | 18 | 12 | 54   | 14 | 35 | 37 | 48 | 34 | 10  | 15                               | 50                           | 186 |
| GN 722.3-14-20-L-SW | 14                                      | 20 | 6.1       | 6.1        | 7.5 | 1.5 | 10 | 7.5 | 18 | 12 | 54   | 14 | 35 | 37 | 48 | 34 | 10  | 15                               | 50                           | 199 |
| GN 722.3-14-20-L-ZB | 14                                      | 20 | 6.1       | 6.1        | 7.5 | 1.5 | 10 | 7.5 | 18 | 12 | 54   | 14 | 35 | 37 | 48 | 34 | 10  | 15                               | 50                           | 199 |
| GN 722.3-16-30-L-SW | 16                                      | 30 | 10.1      | 10.1       | 15  | 5   | 15 | 14  | 34 | 10 | 83   | 20 | 54 | 55 | 80 | 55 | 17  | 30                               | 110                          | 846 |
| GN 722.3-16-30-L-ZB | 16                                      | 30 | 10.1      | 10.1       | 15  | 5   | 15 | 14  | 34 | 10 | 83   | 20 | 54 | 55 | 80 | 55 | 17  | 30                               | 110                          | 846 |
| GN 722.3-20-30-L-SW | 20                                      | 30 | 10.1      | 10.1       | 15  | 5   | 15 | 14  | 34 | 10 | 83   | 20 | 54 | 55 | 80 | 55 | 17  | 30                               | 110                          | 863 |
| GN 722.3-20-30-L-ZB | 20                                      | 30 | 10.1      | 10.1       | 15  | 5   | 15 | 14  | 34 | 10 | 83   | 20 | 54 | 55 | 80 | 55 | 17  | 30                               | 110                          | 863 |

GN 722.3-A4

STAINLESS STEEL

| Description         | d1<br>Pin -0.05/-0.25<br>Bore +0.1/+0.3 | s  | b<br>+0.3 | d2<br>+0.2 | h1  | h2  | h3 | k1  | k2 | k3 | l1 ≈ | l2 | l3 | l4 | l5 | m  | A/F | Spring load<br>in N ≈<br>initial | Spring load<br>in N ≈<br>end | ⚖   |
|---------------------|---|----|-----------|------------|-----|-----|----|-----|----|----|------|----|----|----|----|----|-----|----------------------------------|------------------------------|-----|
| GN 722.3-8-20-R-A4  | 8                                       | 20 | 6.1       | 6.1        | 7.5 | 1.5 | 10 | 7.5 | 18 | 12 | 54   | 14 | 35 | 37 | 48 | 34 | 10  | 15                               | 50                           | 160 |
| GN 722.3-10-20-R-A4 | 10                                      | 20 | 6.1       | 6.1        | 7.5 | 1.5 | 10 | 7.5 | 18 | 12 | 54   | 14 | 35 | 37 | 48 | 34 | 10  | 15                               | 50                           | 170 |
| GN 722.3-12-20-R-A4 | 12                                      | 20 | 6.1       | 6.1        | 7.5 | 1.5 | 10 | 7.5 | 18 | 12 | 54   | 14 | 35 | 37 | 48 | 34 | 10  | 15                               | 50                           | 181 |
| GN 722.3-14-20-R-A4 | 14                                      | 20 | 6.1       | 6.1        | 7.5 | 1.5 | 10 | 7.5 | 18 | 12 | 54   | 14 | 35 | 37 | 48 | 34 | 10  | 15                               | 50                           | 190 |
| GN 722.3-16-30-R-A4 | 16                                      | 30 | 10.1      | 10.1       | 15  | 5   | 15 | 14  | 34 | 10 | 83   | 20 | 54 | 55 | 80 | 55 | 17  | 30                               | 110                          | 831 |
| GN 722.3-20-30-R-A4 | 20                                      | 30 | 10.1      | 10.1       | 15  | 5   | 15 | 14  | 34 | 10 | 83   | 20 | 54 | 55 | 80 | 55 | 17  | 30                               | 110                          | 862 |
| GN 722.3-8-20-L-A4  | 8                                       | 20 | 6.1       | 6.1        | 7.5 | 1.5 | 10 | 7.5 | 18 | 12 | 54   | 14 | 35 | 37 | 48 | 34 | 10  | 15                               | 50                           | 160 |
| GN 722.3-10-20-L-A4 | 10                                      | 20 | 6.1       | 6.1        | 7.5 | 1.5 | 10 | 7.5 | 18 | 12 | 54   | 14 | 35 | 37 | 48 | 34 | 10  | 15                               | 50                           | 170 |
| GN 722.3-12-20-L-A4 | 12                                      | 20 | 6.1       | 6.1        | 7.5 | 1.5 | 10 | 7.5 | 18 | 12 | 54   | 14 | 35 | 37 | 48 | 34 | 10  | 15                               | 50                           | 181 |
| GN 722.3-14-20-L-A4 | 14                                      | 20 | 6.1       | 6.1        | 7.5 | 1.5 | 10 | 7.5 | 18 | 12 | 54   | 14 | 35 | 37 | 48 | 34 | 10  | 15                               | 50                           | 190 |
| GN 722.3-16-30-L-A4 | 16                                      | 30 | 10.1      | 10.1       | 15  | 5   | 15 | 14  | 34 | 10 | 83   | 20 | 54 | 55 | 80 | 55 | 17  | 30                               | 110                          | 831 |
| GN 722.3-20-30-L-A4 | 20                                      | 30 | 10.1      | 10.1       | 15  | 5   | 15 | 14  | 34 | 10 | 83   | 20 | 54 | 55 | 80 | 55 | 17  | 30                               | 110                          | 862 |

